

2. The Astronomical Context

Much of astronomy is about positions so we need coordinate systems to describe them.

2.1 Angles and Positions

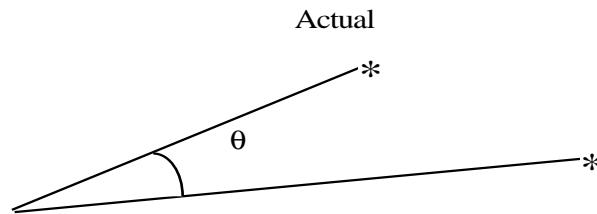

Fig. 2-1

Position usually means angle.

Measurement accuracy for small angles depends on wavelength (and on detectors). Today we have accuracies $\Delta\theta$ approaching

0.01'' - 0.001'' -optical

0.0001'' - radio - VLBI

2'' - X-rays - spacecraft limited

1° - γ -rays - detector limited.

Note that $1^\circ = 60' = 3600''$

$$1 \text{ radian} = \frac{360^\circ}{2\pi} = 57.3^\circ = 206,265''$$

$$1 \text{ m rad} = 10^{-3} \text{ rad} = 3.5 \text{ arcmin} = 3.5'$$

$$1 \mu \text{ rad} = 10^{-6} \text{ rad} = 0.21 \text{ arcsec} = 0.21''$$

2.1.1 Coordinate systems in the sky

You are familiar with Cartesian coordinates (x, y, z) ,

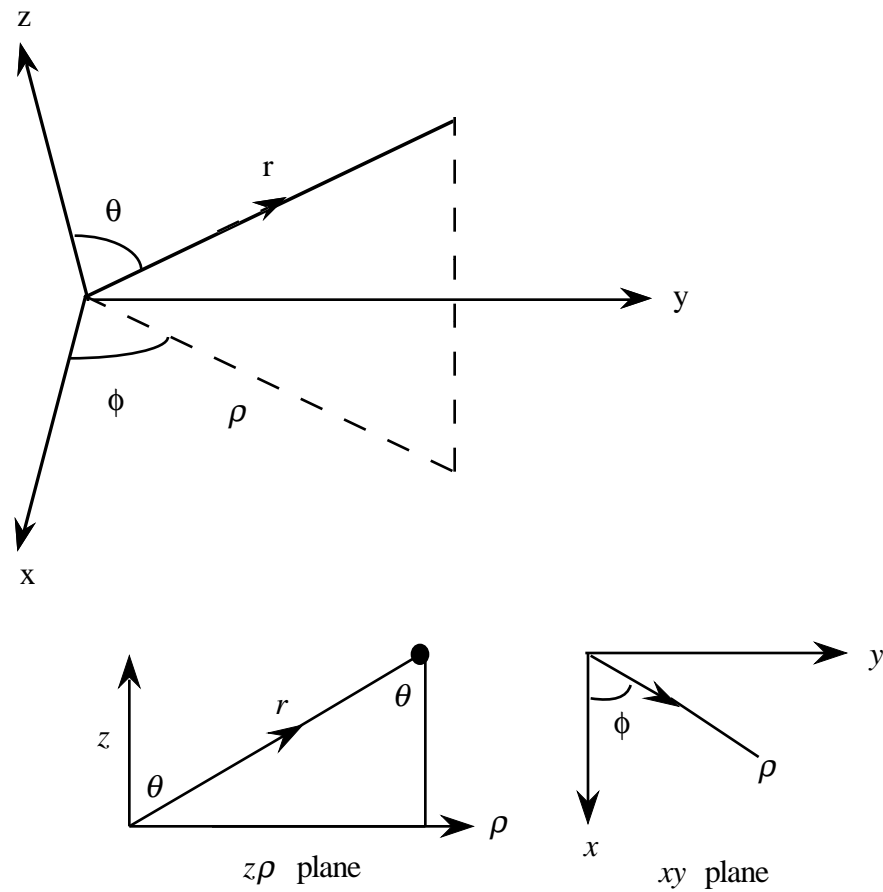

Fig. 2-2

spherical coordinates (r, θ, ϕ) and cylindrical coordinates (ρ, ϕ, z) . They are related by

$$x = r \sin \theta \cos \phi = \rho \cos \phi$$

$$y = r \sin \theta \sin \phi = \rho \sin \phi$$

$$z = r \cos \theta = z$$

Equatorial coordinates (α, δ) or (RA, DEC):

In astronomy, we use spherical coordinate systems and usually the *celestial equatorial* system. The *celestial sphere* has its origin at the center of the Earth and its radius is indefinitely large. To specify a point on the surface of the celestial sphere astronomers use *declination* (DEC or δ) and *right ascension* (RA or α) instead of the latitude and longitude used to specify location on the surface of the Earth. The axis of the Earth points in a constant direction in space which is chosen to be the North Celestial Pole at a declination of 90° . The South Celestial Pole is in the opposite direction at -90° DEC. The celestial equator defines 0° DEC. It is chosen to be the extension of the equatorial plane of the Earth into space. The longitude-like coordinate is specified in hours with 24 hours = 360° . The chosen zero point for RA is the vernal equinox (see Fig. 2-3). The RA of the Sun is zero at the vernal equinox and six months later at autumnal equinox it is 12 hrs. Its declination varies through the year from 23.5° to -23.5° , the angle between the ecliptic and the equatorial plane.

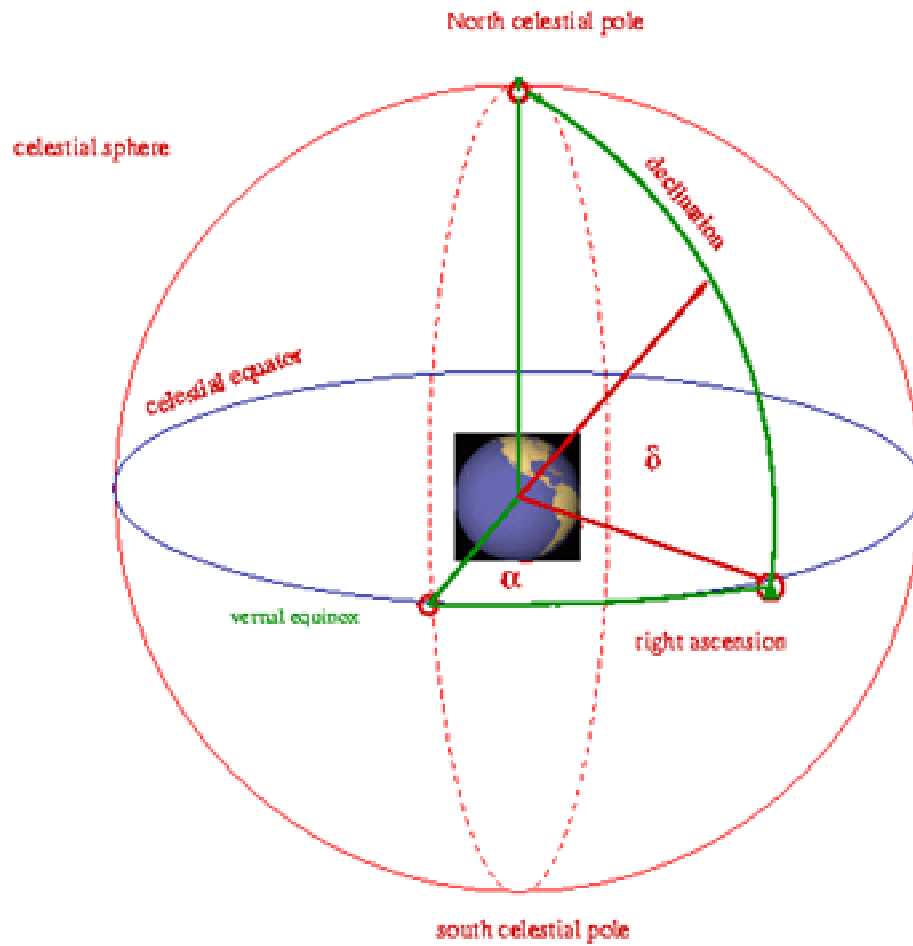

Fig. 2-3

γ is the origin = vernal equinox

DEC δ is like latitude

RA α is like longitude

The stars would have a fixed RA and DEC except that the spin-axis of the Earth precesses which since the equator is perpendicular to the spin causes a drift in

the coordinate system. (The process occurs physically because the Earth experiences a net torque from the gravity of the Earth-Moon system). The period is 26,000 years. The vernal equinox moves West along the ecliptic at a rate of $360^\circ/26,000$ years equal to $50''$ per year (see Fig. 1-1). The changes in the positions of stars are easily detectable.

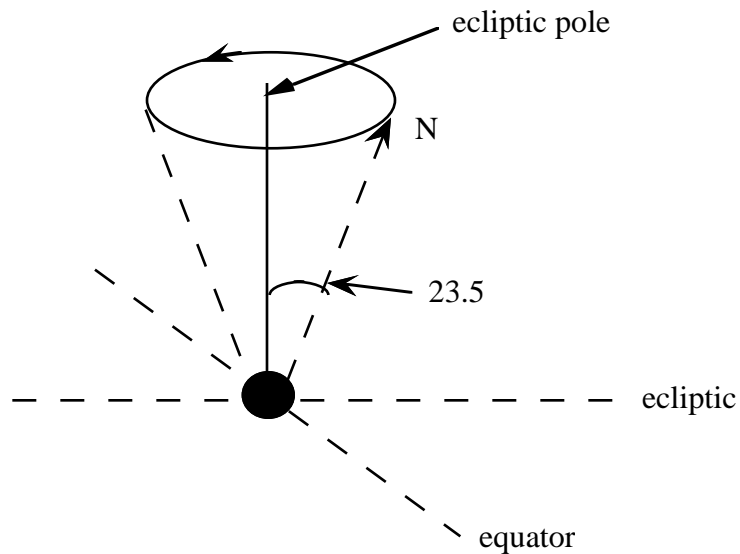

Fig. 2-4

Positions are accordingly referred to a standard epoch in time and are then corrected for the effects of precession. Two standards now in use are called B1950 and J2000.

Galactic coordinates (l , b)

For positions in the Milky Way Galaxy, galactic coordinates of latitude and longitude are often employed. The equator is the central plane of the Galaxy. The origin is the center of the Galaxy. Longitude l is measured eastwards around the galactic equator from 0° at the center in the direction from the Sun to 360° . Latitude b varies from 90° at the North Galactic Pole (NGP) to -90° at the South Galactic Pole (SGP). The galactic plane intersects the celestial equator at an angle of 62.6° .

2.1.2. Angular separations

To determine the angular separation of two objects given their equatorial coordinates (α_1, δ_1) and (α_2, δ_2) transform to Cartesian coordinates

$$x = \cos \delta \cos \alpha$$

$$y = \cos \delta \sin \alpha$$

$$z = \sin \delta .$$

Then evaluate for unit vectors $\hat{\mathbf{r}}_1 \cdot \hat{\mathbf{r}}_2$

$$\hat{\mathbf{r}}_1 \cdot \hat{\mathbf{r}}_2 = \cos \theta = x_1 x_2 + y_1 y_2 + z_1 z_2 .$$

Keep in mind that for the discussion here, the (xyz) coordinates refer to unit length.

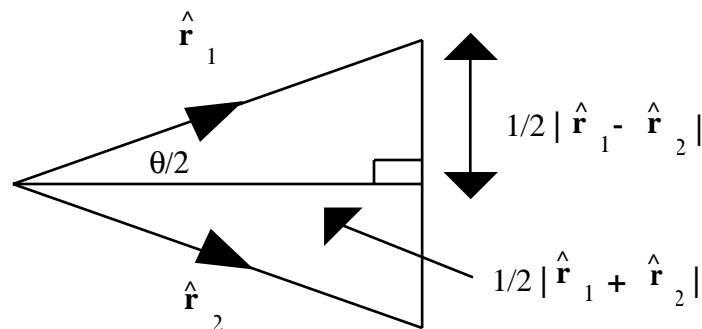

Fig. 2-5

If θ is small, $\cos \theta \sim 1$ and this formula is not useful. Instead from the diagram we obtain

$$\tan \frac{1}{2} \theta \sim \frac{1}{2} \theta = \frac{|\hat{\mathbf{r}}_1 - \hat{\mathbf{r}}_2|}{|\hat{\mathbf{r}}_1 + \hat{\mathbf{r}}_2|} = \left\{ \frac{(x_1 - x_2)^2 + (y_1 - y_2)^2 + (z_1 - z_2)^2}{(x_1 + x_2)^2 + (y_1 + y_2)^2 + (z_1 + z_2)^2} \right\}^{1/2} .$$

2.1.3 Solid angle

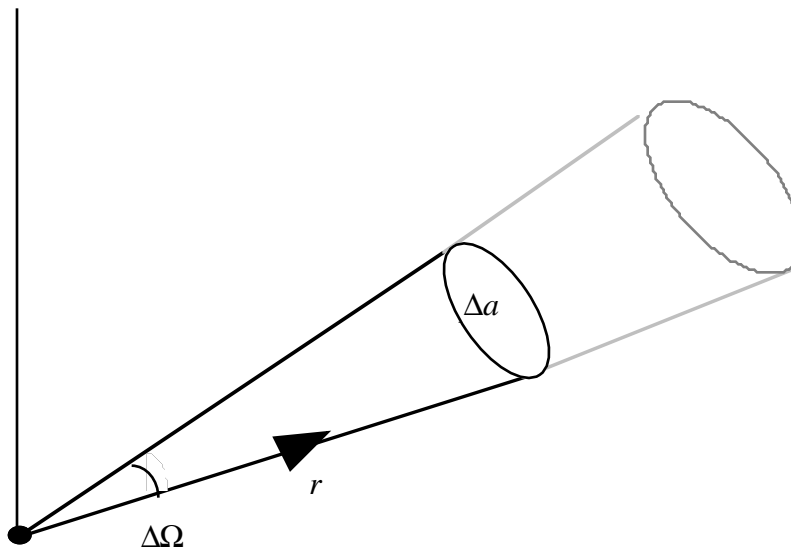

Fig 2-6

When observing an object from a point the solid angle Ω subtended by the object is the interior angle of the cone containing all the lines of sight, joining any point of the object to the origin. From Fig. 2.7, since the sides of the small shaded area at the spherical surface of an object are $r d\theta$ and $r \sin\theta d\phi$, the area $\Delta a = r^2 \sin\theta d\theta d\phi$ or $\Delta a = r^2 d\Omega$. Since Δa increases as r^2 , $\Delta \Omega$ is independent of r . The unit of solid angle is the steradian (*sr* or *ster*) with the entire surface subtending

an angle $4\pi sr$ (since then $\Delta a = 4\pi r^2$).

Note that in spherical polar coordinates

$$d\Omega = \sin \theta d\theta d\phi$$

$$= -d(\cos \theta)d\phi$$

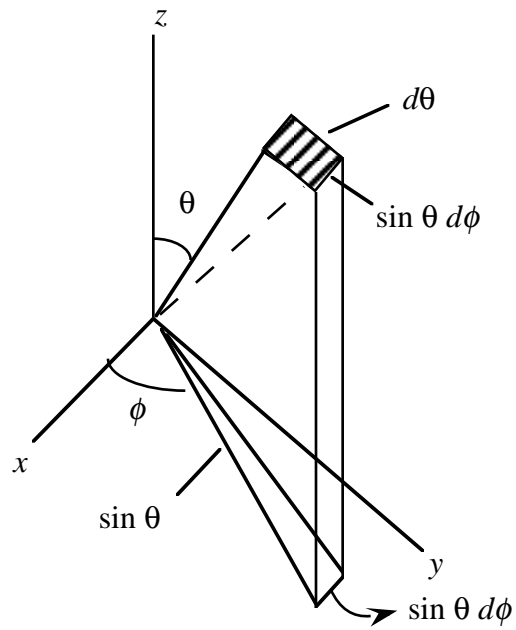

Fig. 2.7

The angular size of an object in the sky can be expressed in square radians or square degrees. The surface area of a unit sphere is 4π square radians so the total number of square degrees in the sky is

$$4\pi \left(\frac{360}{2\pi} \right)^2 = 41252.96 \sim 40,000.$$

A circle of radius r at distance d has an apparent area $\pi r^2/d^2 = \pi\theta^2$ square radians = $\pi \left(\frac{360}{2\pi} \right)^2 \theta^2$ square degrees. The Sun and Moon are each close to 0.5° in diameter so that their areas are $\pi(0.5/2)^2 = 0.20$ square degrees or $1/200,000$ of the celestial sphere.

2.2 Brightness Measurements

2.2.1 Flux and UBV system

Flux, F , is the energy crossing through unit area (of a detector) per unit time. Flux has units of $\text{erg cm}^{-2} \text{s}^{-1}$ or W s^{-1} . If source of energy is an isotropic point source at distance D , F is related to the luminosity L by

$$F = L/4\pi D^2$$

2.2.2 Apparent magnitudes

Astronomers use a strange scale to describe the flux from a star that dates back 2000 years. The brighter the star, the smaller the magnitude. First magnitude stars have $m = 1$, second magnitude stars have $m = 2$ and so on. The very brightest stars have negative magnitudes. The magnitude of the Sun is -26.81. Astronomers use magnitudes with five magnitudes corresponding to a factor of 100. A difference of one magnitude is a factor

$$100^{1/5} = 10^{2/5} = 10^{0.4} = 2.512.$$

The relative fluxes F_1 and F_2 from two stars of apparent magnitudes m_1 and m_2 are given by the difference in magnitudes according to

$$\frac{F_2}{F_1} = 100^{-1/5(m_2 - m_1)} = 10^{-0.4(m_2 - m_1)}$$

or

$$m_2 - m_1 = -2.5 \log_{10}(F_2/F_1)$$

or

$$m_1 + 2.5 \log F_1 = m_2 + 2.5 \log F_2 = \text{constant.}$$

These are ratios but once we specify the flux F corresponding to any particular

magnitude, say $m=0$, the constant is determined and all magnitudes are defined.

The stellar radiation is a function of wavelength λ or frequency ν . Thus stars have different *colors* and the fluxes at different wavelengths or in different wavelength bands can be compared. In astronomy, the spectrum is broken down into standard wavelength bands by standard filters, used at all observatories, and the stars are characterized by their fluxes in the different bands. The bands are *U* (ultraviolet), *B* (blue), *V* (visual or optical), *H* (red) and (*I,J,K*) increasing infrared.

The wavelength separation is achieved by filters. The transmission efficiencies through the *UBV* filters are shown in the figure as a function of wavelength λ . (A perfect filter would have the shape of a rectangle.)

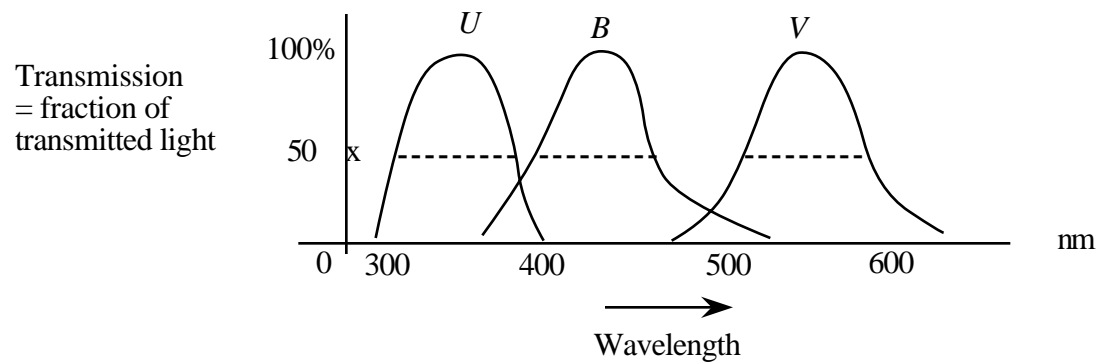

Fig. 2-8

In reality, filters are classified by their central wavelength and spectral band widths.

The table gives numerical data on the central wavelengths and the effective band widths ($1 \mu = 1000 \text{ nm}$.)

Band	<i>U</i>	<i>B</i>	<i>V</i>	<i>H</i>	<i>I</i>	<i>J</i>	<i>K</i>
Central Wavelength (nm)	365	440	550	700	1000	1250	2200
Effective width defined by area under curve (μ)	0.068	0.098	0.089	0.220	0.240	0.380	0.480

The naked eye is approximately a *V* filter. It extends from 460 to 640 nm.

The total flux is an integral over frequency ν

$$F = \int F_{\nu} d\nu$$

or wavelength λ

$$F = \int F_{\lambda} d\lambda .$$

F_{ν} has units $\text{ergs cm}^{-2} \text{s}^{-1} \text{Hz}^{-1}$ and F_{λ} has units $\text{ergs cm}^{-2} \text{s}^{-1} \text{wavelength}^{-1}$.

Frequency and wavelength are related by

$$\nu = \frac{c}{\lambda} .$$

c is velocity of light $3 \times 10^{10} \text{ cm s}^{-1}$.

By definition

$$|F_{\lambda}d\lambda| = |F_{\nu}d\nu|$$

so

$$F_{\lambda} = \frac{c}{\lambda^2} F_{\nu}, \quad F_{\nu} = \frac{c}{\nu^2} F_{\lambda}.$$

Astronomers usually use Angstroms (\AA) or microns (μ) for wavelengths

$$1\text{\AA} = 0.1 \text{ nm} = 10^{-8} \text{ cm}$$

$$10,000\text{\AA} = 1000 \text{ nm} = 1\mu = 10^{-6} \text{ m}.$$

Fluxes in the various bands are labelled F_U, F_B, F_V etc. They are defined as integrals over wavelength. For example.

$$F_U = \int_U F_{\lambda} T_{\lambda} d\lambda$$

is the flux in the ultraviolet band, where T_{λ} is the transmission function for the U filter. The total flux in all the bands

$$F = F_U + F_B + \dots$$

is the *bolometric* flux and the corresponding magnitude is the bolometric magnitude.

Magnitudes can now be defined for the different wavelength bands (or colors) of any given star. They are written m_U, m_B, m_V or as the capital letters U, B, V , etc. The difference between a star's bolometric magnitude m_{bol} and its visual magnitude m_V is the *bolometric correction*

$$BC = m_{bol} - m_V = m_{bol} - V .$$

BC is always a negative number.

The difference in magnitudes in the various wavelength bands for the same star is called a color index, e.g.

$$m_B - m_V = B - V$$

and it characterizes the color of the star.

Using $m_X - m_V = X - V$ for any wavelength band X , the ratio of fluxes in different bands X and V is

$$\frac{F_X}{F_V} = 10^{-0.4(X-V)} .$$

(The magnitude scale was introduced with $m_V = V = 0$ for a star of the first magnitude and fainter stars were of second, third, etc. magnitude).

The table reports the visual magnitude and color index for several stars.

Star	V	$B-V$
Arcturus (α Boo)	-0.06	1.23
Vega (α Lyr)	0.04	0.00
Capella (α Aur)	0.80	0.79
Betelgeuse (α Ori)	0.80	1.85
Aldebaran (α L Tau)	0.85	1.53

Remember, the smaller the magnitude the brighter the star, so all stars in the table are reddened compared to Vega because $B-V$ is positive.

To provide quantitative estimates of typical fluxes in the different bands, average values of F_U , F_B , F_V ... for $m=0$ stars have been determined for a group of Vega-type stars. The Table lists the central wavelengths in nm, bandwidths in μ and $\log \overline{F}_\lambda$ for the different bands. \overline{F}_λ is given in $\text{ergs cm}^{-2} \text{s}^{-1} \mu^{-1}$.

Band	<i>U</i>	<i>B</i>	<i>V</i>	<i>H</i>	<i>I</i>	<i>J</i>	<i>K</i>
Central Wavelength (nm)	365	440	550	700	1000	1250	2200
Effective width defined by area under curve in μ	0.068	0.098	0.089	0.220	0.240	0.380	0.480
$\log \bar{F}_\lambda$ (ergs $\text{cm}^{-2} \text{s}^{-1} \mu^{-1}$) ($m=0$)	-4.37	-4.18	-4.42	-4.76	-5.08	-5.48	-6.40

To obtain F_U , say, from the Table, multiply \bar{F}_λ by the band width 0.068 in microns.

For example, if $m_V = V = 0$, the table gives

$$F_V = 10^{-4.42} \frac{\text{erg}}{\text{cm}^2 \mu \text{s}} (0.089 \mu) = 3.4 \times 10^{-6} \text{erg cm}^{-2} \text{s}^{-1}.$$

So for the star Betelgeuse, $V = 0.8$

$$\begin{aligned} F_V &= 3.4 \times 10^{-6} 10^{-0.4(0.8)} \text{erg cm}^{-2} \text{s}^{-1} \\ &= 1.6 \times 10^{-6} \text{erg cm}^{-2} \text{s}^{-1} \end{aligned}$$

Note that because $10^{-0.4} = 0.398$ is not much different from $e^{-1} = 0.367$, 1 magnitude is approximately 1 e-fold.

2.2.3 Absolute Magnitudes

The apparent magnitude of a star would change if it were at a different

distance. Absolute magnitudes are defined as the magnitudes the stars would have if they were the standard distance $D= 10\text{pc}$ away, and they are denoted by M_U , M_B , etc.

Since flux $\propto D^{-2}$,

$$\frac{F(10\text{pc})}{F(\text{obs})} = 10^{-0.4(M-m)} = (D/10\text{pc})^2 .$$

$$\text{So } 2 \log (D/10\text{pc}) = -0.4(M-m)$$

$$m = M + 5 \log(D/10\text{pc})$$

$$m = M + 5 \log D - 5 \text{ with } D \text{ in pc}$$

$5 \log D - 5$ is called the *distance modulus*.

The Sun has $M_V = 4.76$ and would be barely visible if it were at 10pc.

The absolute magnitude and the luminosity are properties of the object. If we know either, measuring the apparent magnitude m gives the distance of the star.

Color indices refer to the same star. They are independent of distance and equal to the difference in absolute magnitudes, e.g.

$$B-V = m_B - m_V = M_B - M_V$$

For any distance D ,

$$\frac{L_2}{L_1} = \frac{F_2(D)}{F_1(D)} = \frac{F_2(10\text{pc})}{F_1(10\text{pc})} = 10^{-0.4(M_2-M_1)} .$$

2.2.4 Spectra

In the spectra of stars are emission and absorption lines. Atoms in a gas can emit light at specific wavelengths or frequencies and from the observed radiation we can identify the emitting species. They can absorb light at specific frequencies and also at high frequencies or short wavelengths they can absorb over a continuum. Hundreds and thousands of lines may be seen in emission, fewer in absorption, depending on the object. When the lines overlap, the spectrum appears to be a continuum. (Helium, previously unknown on Earth, was discovered spectroscopically on the Sun in 1868.)

Here is a spectrum showing emission lines of an object called a planetary nebula. The individual line wavelengths identify the emitting species.

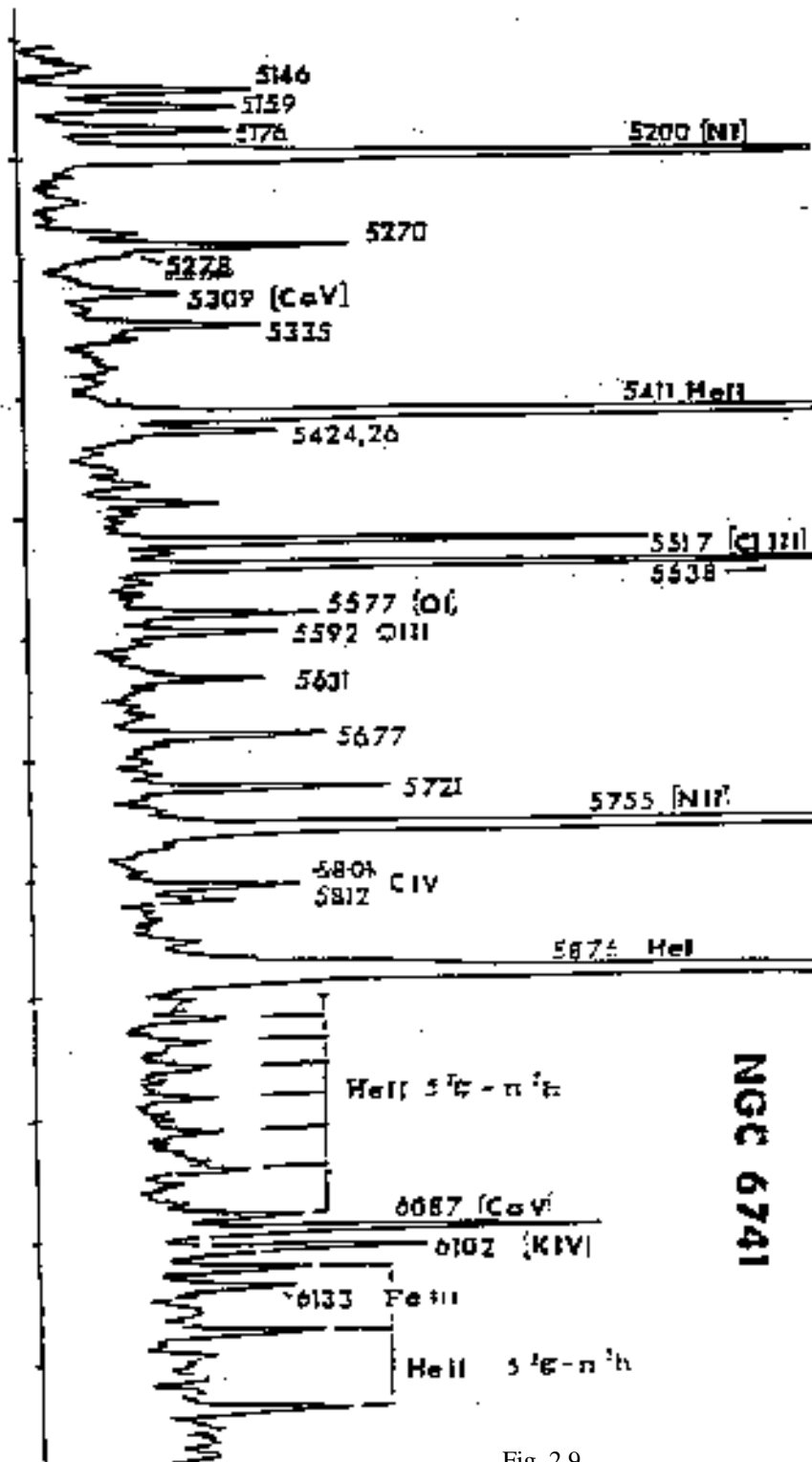

Fig. 2.9

2.3 Velocity measurements

From observations of spectral emission and absorption lines, velocities can be determined. If the emitting or absorbing species is moving radially away or towards the observer there is a shift in the wavelength, called the *Doppler* shift.

Light propagates as a wave. If the observer and the source are moving away from each other with a velocity v , the travel time is increased and the frequency of the wave is decreased by a factor $1+v/c$. The wavelength is increased so

$$\lambda = \lambda_0 \left(1 + \frac{v}{c} \right)$$

where λ_0 is the rest wavelength and there is a red shift in the wavelength. If the observer and the source are moving towards each other

$$\lambda = \lambda_0 \left(1 - \frac{v}{c} \right)$$

and there is a blue shift. These are the non-relativistic limits. If v is large, relativistic time dilation must be taken into account and the formulae become

$$\lambda = \lambda_0 \left\{ \frac{1 + \frac{v}{c}}{1 - \frac{v}{c}} \right\}^{1/2} \quad \text{or} \quad v = v_0 \left\{ \frac{1 - \frac{v}{c}}{1 + \frac{v}{c}} \right\}^{1/2}$$

(see Ostlie and Carroll, p. 109).

If the observer and source are moving away from each other, the increase in wavelength towards the red is described by the red shift z where

$$z = \frac{\lambda}{\lambda_o} - 1 = \frac{v_o}{v} - 1$$

$$\sim \frac{v}{c} \text{ if } v \text{ is small.}$$

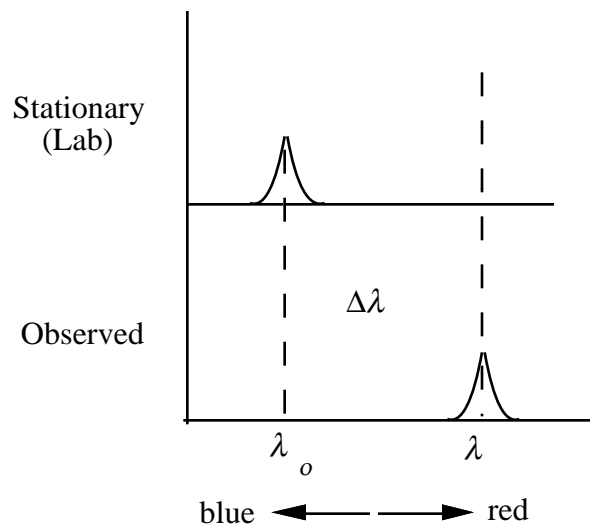

2.3.1 Proper Motion

Proper motion is the actual motion of the object (star) in the plane of the celestial sphere. It appears as a change in the angular equatorial coordinates and is determined by the transverse velocity. It is usually written in arcsec per year.

Barnard's star has an annual proper motion of $10.34''$ — motion is cumulative—it adds up.

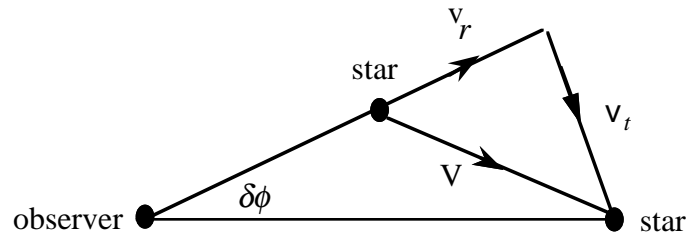

If $\delta\phi$ is the change in angle in a time δt ,

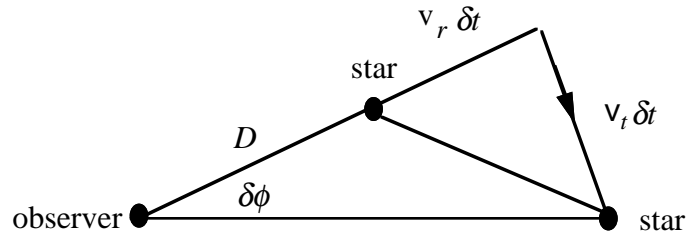

$$v_t \delta t = (D + v_r \delta t) \delta \phi$$

$$v_t = D \frac{\delta \phi}{\delta t} + v_r \delta \phi .$$

$$\text{Let } \delta \phi \rightarrow 0$$

$$v_t = D \dot{\phi}$$

If the rate of change of the angle ϕ is measured in radians per year, v_t is in pc per year. The rate of change of the angle ϕ , $\dot{\phi}$ is known as the star's proper motion.

2.4 Distance Measurements

- I) Solar system - radar reflection measures round trip time.
- II) Triangulation
- III) Parallax
- IV) Luminosity - standard candles

$$F = L/4\pi D^2$$

can be used if L is known, e.g., it may be characteristic of the object as in Cepheid variables. In Cepheid variables, the variability period is related to L . RR Lyrae stars (another kind of variable star) and Tully-Fisher galaxies (in which L is inferred from the rotational velocity) can be used similarly. The fading of radiation from a supernova of type 1a may also be used. Extinction of light by intervening material complicates the picture.

- V) Angular sizes of “standard rods”

Same as (IV): find a distant object that is the same as a nearby one for which the size is known. If the true size of the nearby object is Γ and the distant one is θ , distance $D = \Gamma/\theta$.

- VI) Hubble law

For galaxies. Universe is expanding—all galaxies are moving away. Assumption is that radial velocity is proportional to distance

$$V_r = HD .$$

$$H = (50-70) \text{ km s}^{-1} \text{ Mpc}^{-1}$$

usually written

$$H = 100h \text{ km s}^{-1} \text{ Mpc}^{-1} \text{ where } h = (0.5-1.0).$$

V_r is found by measuring red shifts of emission lines or absorption lines.